

PcCR 1417 ACL4 System

Automatic Cassette Loading Version



Installation Manual

Catalog number: AT095047-01

November, 2004



OREX Ltd. is a market innovator in the field of portable Computed Radiography Technologies—designed and priced for low-volume clinic or field unit needs.

Founded in 1995 under the name of Digident, the company initially entered the market of desktop dental radiography providing high quality, portable CR reading units for dental and orthodontic professionals around the world. The secret of Digident/OREX's rapid success lies in the best cost-performance ratio on the market.

OREX designs, manufactures and markets phosphor image laser scanners. These units replace the traditional x-ray film and light box. The scanners allow the user to immediately read the x-ray image from the phosphor plate, and transfer it to a DICOM 3 compatible digital computer file. Once transferred, users can manipulate the digital image for close-up screening, or transmit it for long-distance consultation. After each scan, the phosphor plates are automatically erased by the unit, ready for re-use.

OREX provides clients with a full solution including phosphor image plates, laser readers, software for image processing, storage, retrieval and communication in Picture Archiving and Communications System (PACS) compatible format.

The company's mission is to become a leading provider of compact personal CR systems. Following the successful penetration of the global dental market, the company changed its name from Digident to OREX and expanded its markets and product lines to serve the *dental, medical, military, industrial and veterinary* fields.

“We are committed to assisting our customers in obtaining maximum value from OREX products by providing excellent support at exceptional value.”

Technical Support

<i>Israel Headquarters:</i>	Tel: ++972-4-959-1331
	Fax: ++972-4-959-1262
	E-mail: support@orex-cr.com
<i>US Office:</i>	Tel: ++1-617-244-9000
	Toll free: 1-888-844-7775 (within
US only)	
	Fax: ++1-617-244-9020
	E-mail: salesusa@orex-cr.com

Document Part Number: AT095047-01

Printed in Yokneam, Israel 2002



Copyright © 2002, all rights reserved

Safety Summary

LIFTING HAZARD

The PcCR 1417 scanner weights 40 Kg (88lb).



- Do not try to lift the scanner by yourself.
- Always seek assistance from another person.
- Lifting equipment that is too heavy may result in serious injury to personnel and/or damage to equipment.



WARNING

The PcCR1417 scanner is a CLASS 1 Laser product.

- Do not remove the scanner cover
- Cover removal should be done only by authorized service personnel



Laser Safety Instructions

1. During normal operation, to prevent the surrounding area from being exposed to laser, the scanner should always be enclosed in its protective cover. This is
2. During normal operation, the cover should not be removed. Removing the cover should only be done for service purposes by a qualified technician.

Table of Contents

- 1. Terms and Conventions.....1-1**

- 2. Packaging.....2-1**

- 3. Site Preparation.....3-1**
 - 3.1 General 3-1
 - 3.2 Computer Requirements..... 3-1
 - 3.3 Space Requirements 3-1
 - 3.4 Electrical Requirements 3-2
 - 3.5 Environmental Requirements 3-2
 - 3.5.1 Temperature 3-2
 - 3.5.2 Light 3-2

- 4. Installation4-1**
 - 4.1 General 4-1
 - 4.2 On-Site System Configuration 4-2
 - 4.3 Equipment Required For Complete Installation..... 4-3
 - 4.4 Installation process..... 4-4
 - 4.4.1 Connecting the cables..... 4-4
 - 4.4.2 Installing the drivers for the PcCR 1417 4-4
 - 4.4.3 Installing the “Scanner Interface” 4-8
 - 4.4.4 Onyx-Rad Installation 4-16
 - 4.4.5 Licensing the GOP Filters 4-17
 - 4.5 Installation Report 4-20

- 5. Scanner Interface Software.....5-1**
 - 5.1 General 5-1
 - 5.2 Interface Description 5-1

5.2.1	Main Screen.....	5-1
5.2.2	Setup Anatomical	5-3
5.2.3	Setup Image.....	5-6
5.2.4	Setup Configuration	5-8
5.2.5	Setup Operation Update	5-12
5.2.6	Setup Diagnostics	5-13
5.2.7	Setup Automatic Tests	5-15
5.2.8	Setup Advance.....	5-16
5.2.9	Setup About.....	5-18
5.2.10	Image Diagnostics	5-20
6.	Troubleshooting	6-1
7.	Appendix A: Installation Prerequisites.....	7-1
8.	Appendix B: Installation Report	8-1

List of Figures

Figure 1: Closed Box.....	2-1
Figure 2: Open Box	2-1
Figure 3: PcCr 1417 Dimensions	3-2
Figure 4: System Configuration	4-2
Figure 5: Dongle parallel/USB for Onyx-Rad software.....	4-2
Figure 6: Dongle Parallel Plug for GOP filter.....	4-3
Figure 7: CVLicense Window Before GOP Licensing.....	4-17
Figure 8: Setting the GOP License Key	4-18
Figure 9: CVLicense Window After GOP Licensing	4-19
Figure 10: Scanner Interface, Main Screen.....	5-1
Figure 11: Setup Menu, Anatomical tab	5-3
Figure 12: Setup Menu, Image tab	5-6
Figure 13: Setup Menu, Configuration tab.....	5-8
Figure 14: Setup Menu, Operation Update tab	5-12
Figure 15: Setup Menu, Diagnostics tab	5-13
Figure 16: Setup Menu, Automatic Tests tab.....	5-15
Figure 17: Setup Menu, Advance tab.....	5-16
Figure 18: Setup Menu, About tab	5-18
Figure 19: Image Diagnostic screen (Mini Viewer).....	5-20

1. Terms and Conventions

The following abbreviations are used throughout this manual:

Term	Meaning
FSE	Field Service Engineer
PSP	Photo-Stimulate Phosphor
USB	Universal Serial Bus

2. Packaging

The PcCR 1417 is shipped in a custom designed box that protects the scanner. If the PcCR 1417 needs to be returned to Orex or to one of its dealers, the scanner must be repacked in its original box, and must include the CD and the USB cable.



Figure 1: Closed Box

Please use all the protective parts in the box in order to minimum the risk of damage to the scanner.



Figure 2: Open Box

3. Site Preparation

3.1 General

Inform the client about the site preparation requirements prior to installing the PcCR 1417. Without these requirements being met, you cannot complete the installation, and the client’s ability to use the PcCR 1417 properly can not be guaranteed.

3.2 Computer Requirements

Pentium 4, 1.8 GHz (or above)
256 MB RAM (512MB recommended)
Hard drive – 40 GB (or above)
Network adapter (required for Dicom – send)
Operating system – Win 2000
USB Port
NO USB mouse or keyboard
Parallel port
Screen resolution – 1024 x 768 (or above)

3.3 Space Requirements

The PcCR 1417 shall be positioned on a stable surface, with at least 20 cm (~ 8”) free space on every side of the scanner. A long USB cable shall connect the PcCR 1417 scanner to the computer, enabling proper spacing of these units from each other.

The space requirements for the PcCR 1417 (including scanner dimensions and additional space) are shown below:

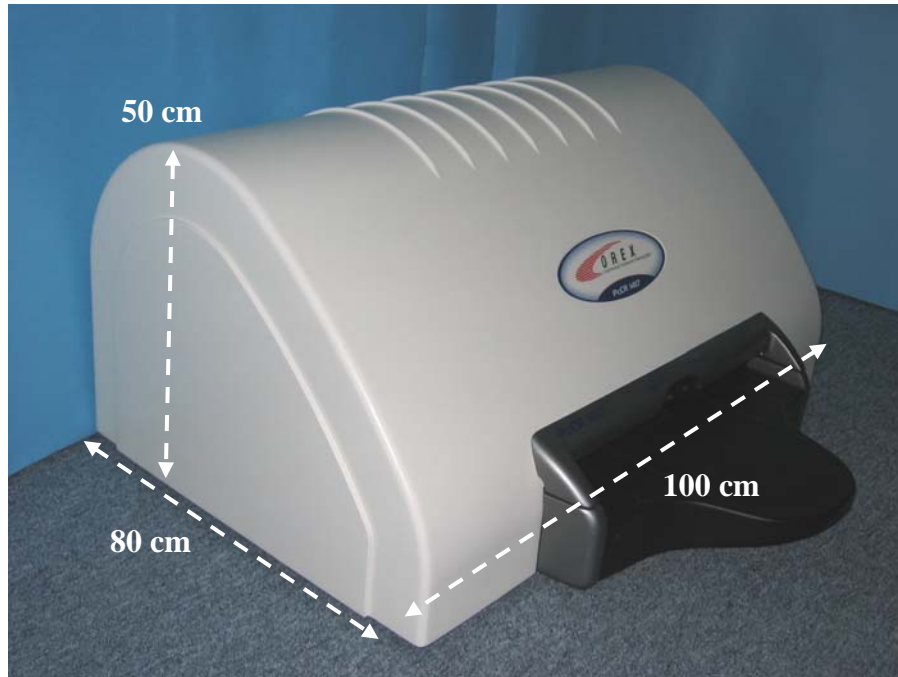

Figure

3: PcCr 1417 Dimensions **Electrical Requirements**

Voltage:	90 V–250 V AC
Frequency:	50Hz–60Hz
Fuses:	Two fuses are located next to the On/Off switch at the back of the scanner. Each fuse protects one of the power supplies. The fuses are 1A (slow blow).
UPS:	Online; 500 VA

3.5 Environmental Requirements

3.5.1 Temperature

Maintain the room temperature between 18°C and 30°C, normal lab conditions; relative humidity 80%, non-condensing.

3.5.2 Light

The PcCR 1417 is sealed and protected from light penetration. However, it is recommended to keep the PcCR 1417 in standard room light, away from exposure to direct sunlight.

The PcCR 1417 uses phosphor plates for acquiring images. The phosphor plates are sensitive to light, and therefore exposure to light should be kept to a minimum. The phosphor plates should

be exposed to light only when they move from the cassette into the PcCR 1417 scanner.

For optimal results, room light is recommended at less than 1000 Lux.

4. Installation

This chapter explains the installation procedure of the PcCR 1417.

The FSE who installs the PcCR 1417 shall follow the steps described herein. Upon completion of the installation, fill out the Installation Report (Appendix B).

4.1 General

On-site installation of the PcCR 1417 shall be carried out by FSEs authorized by Orex, **and will follow the instructions below:**

1. Unpack the PcCR 1417 and position it in the desired location.
2. Verify the integrity of the unit and its components.
3. Plug the system into the electrical outlet, and connect the USB cable to the PC (section 4.4.1.)
4. Plug in the WIBU-KEY (green dongle) supplied with the Onyx-Rad CD to the parallel port on the back of the computer, the green dongle must be the first one connected to the parallel port and then you can connect other dongles to him!!!
5. Plug in the GOP dongle to the parallel port on the back of the computer on the Onyx-rad dongle.
6. Install the software for the PcCR 1417 (section 4.4.2 – 4.4.4.)
7. Test the system's functional operation.
8. Send a completed Installation Report (Appendix B) to Orex service department.

Note: The warranty shall not be issued until Orex service department receives the installation report. **(Warranty will be issued only after the Orex service department receives the installation report)**

4.2 On-Site System Configuration

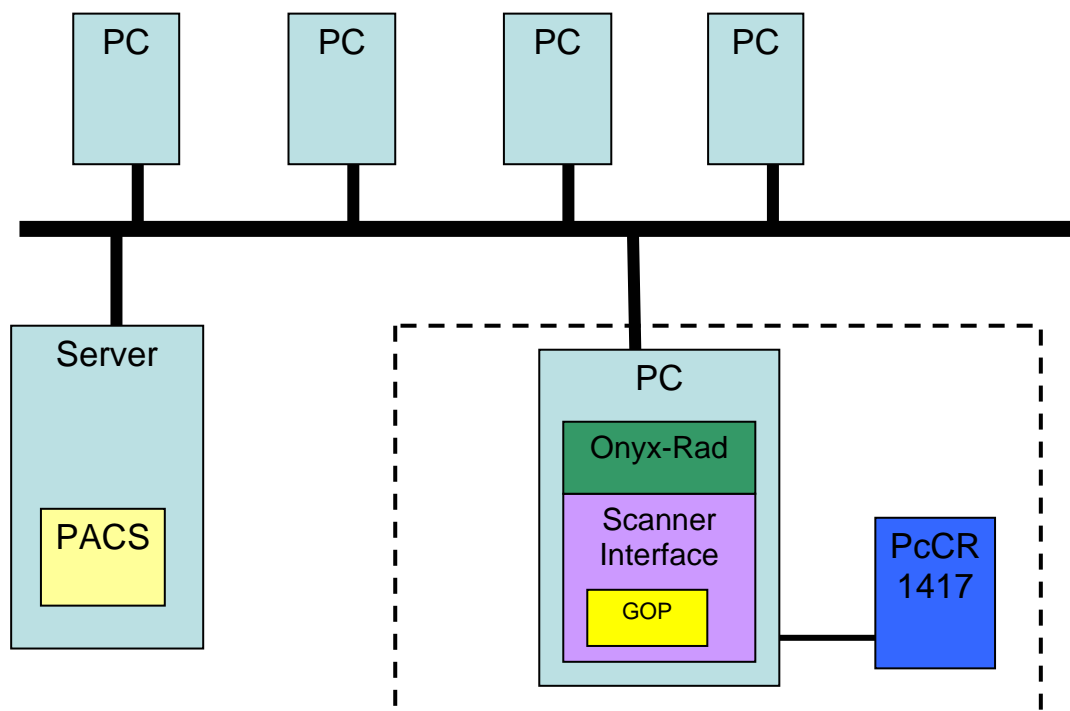

Figure 4: System Configuration

PC – Make sure that the PC you are using meets the requirements described in Section 3.2, Computer Requirements

Scanner interface – Software supplied by Orex with every system

GOP – Enhancements for the scanner interface software for the purpose of image enhancement (requires special dongle connected to the parallel port of the PC)

Please note:

Installation without the GOP causes a non-optimal image quality.

Onyx-Rad– Imaging software installed on the PC for the purpose of acquiring, storing, and Dicom sending the images to different stations

Please note:

Users that do not intend to use Onyx-Rad should skip section 4.4.4.

4.3 Equipment Required For Complete Installation

- PC (refer to “computer requirements” for details)
- Cables: Power cable (not included with the PcCR 1417), USB cable (included with the PcCR 1417)
- “Scanner interface” CD
- “Onyx-Rad” CD
- Dongle parallel/USB for licensing Onyx-Rad software (figure 5).
- Dongle (parallel plug) for licensing GOP filters (figure 6).



Figure 5: Dongle Parallel/USB Plug for Onyx-Rad software



Figure 6: Dongle Parallel Plug for GOP filter

4.4 Installation process

The installation process includes the following:

4.4.1 Connecting the cables

4.4.2 Installing drivers for PcCR 1417

4.4.3 Installing “scanner interface”

4.4.4 Installing Onyx-Rad

4.4.5 Installing the Dongle (license for GOP)

4.4.4 Licensing the GOP filters

4.4.1 Connecting the cables

1. Connect the power cable from the PcCR 1417 to the power outlet.
2. Connect the USB cable (included in the PcCR 1417 box) to the USB port of the PC.

4.4.2 Installing the drivers for the PcCR 1417

1. Turn on the PcCR 1417. The system makes initializations noise. “Found new hardware” screen appears, followed by the installation screen:



2. Click “next”



3. Choose “Search for a suitable...”; then click “Next”



4. Leave only the “specify a location” check-box selected; then click “Next”



5. Insert the “scanner interface” CD in to the CD-Rom drive.
If installation does not begin automatically, Click the “Browse” button.
6. A “Locate file” window appears.
Browse to the CD-Rom.

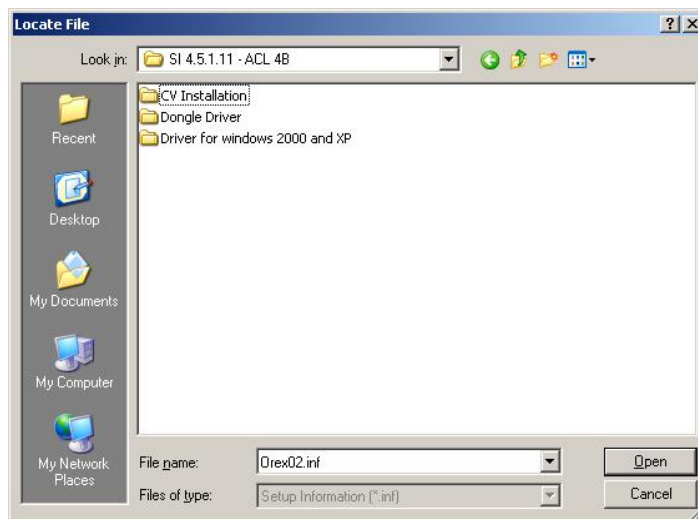

7. Double click the “Driver for windows 2000 and XP” folder.

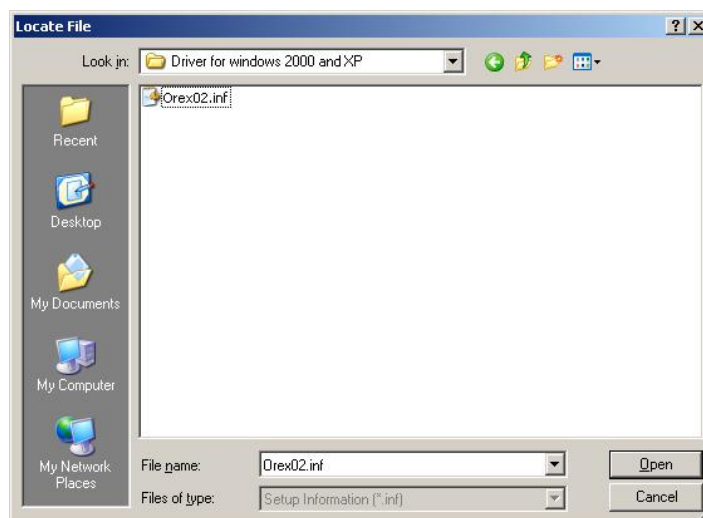

8. Mark the “orex02.inf” file; then click “Open”



9. The Installation Wizard finds the driver for the PcCR 1417.
Click “Next”.
10. Click “Yes” to confirm the driver file



11. The installation wizard completes the installation of the driver.

4.4.3 Installing the “Scanner Interface”

1. Insert the “Scanner Interface” CD into the CD-Rom drive. If installation does not begin automatically, Double-click on “My Computer” and choose the CD-Rom drive. The content of the CD will appear on a new window:

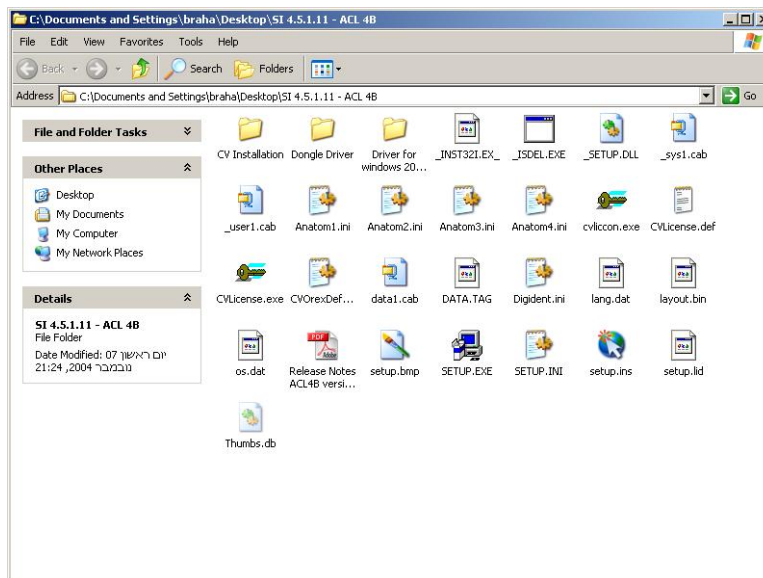

2. Double-click the “setup.exe” file.

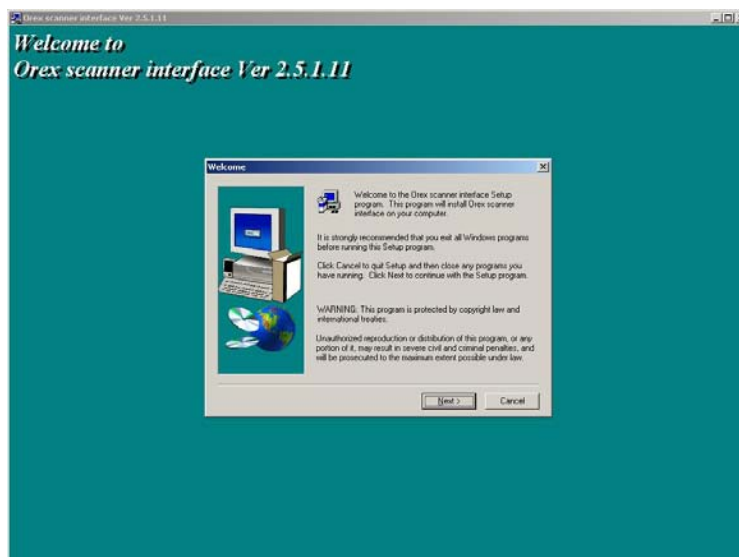

3. The installation of “Scanner Interface” begins. Click “Next”.



4. Click “Next”.

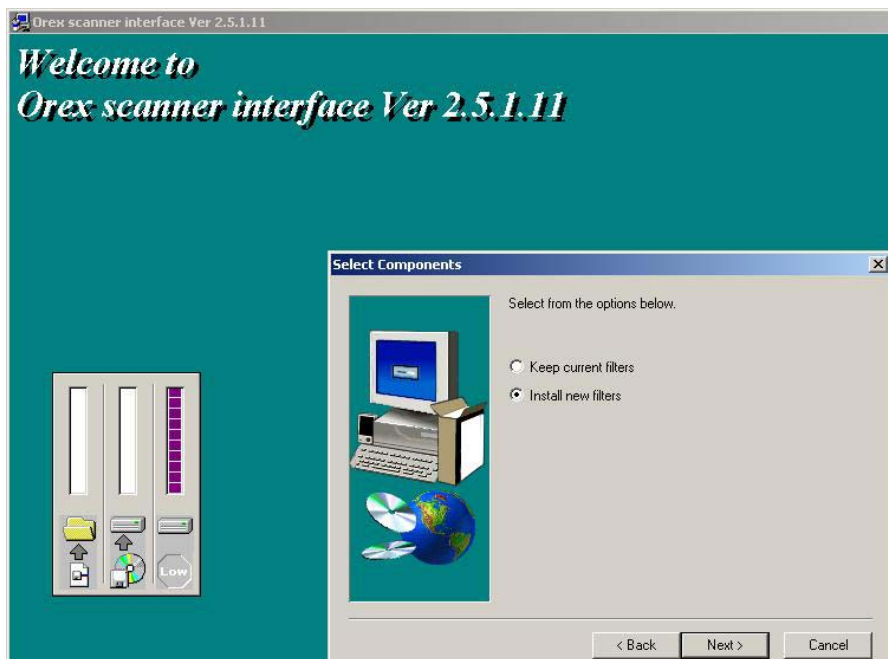

5. Choose “Install new filters” and click “Next”.
The software installs.

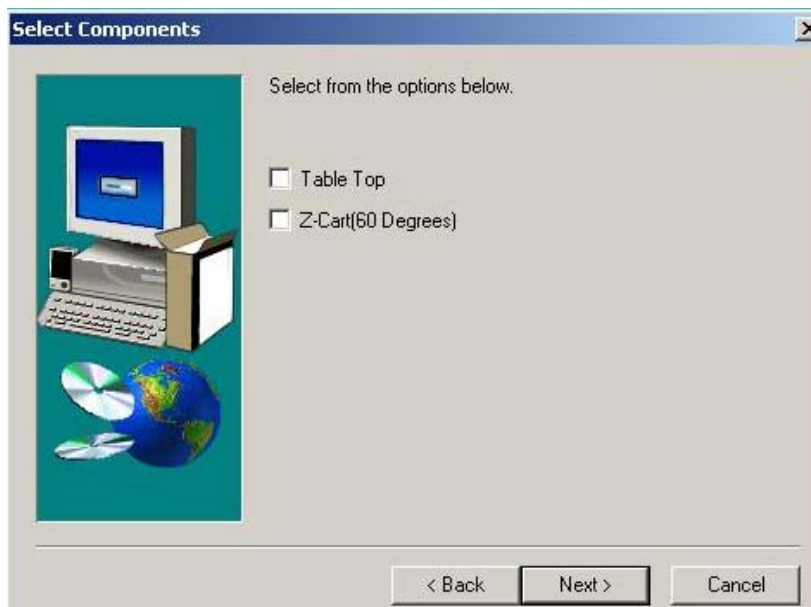
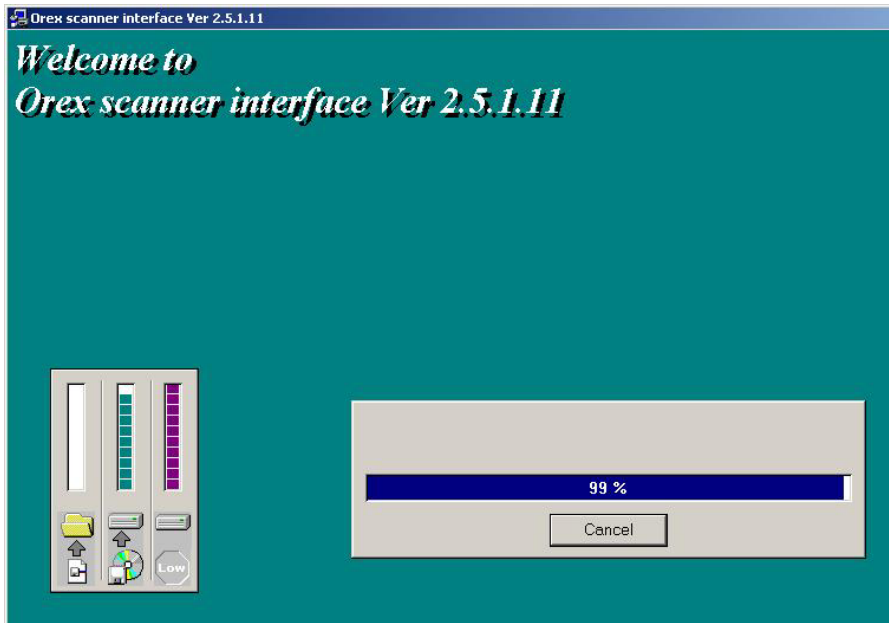

6. Choose the option appropriate to the specific system. Click “Next”.



7. Click Next

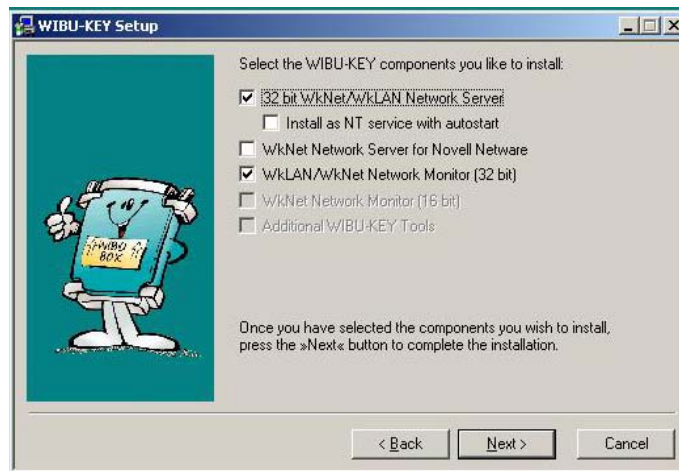

8. Use the default options and Click "Next"



9. Click "Next"



10. When all tasks are completed, click “Next”.

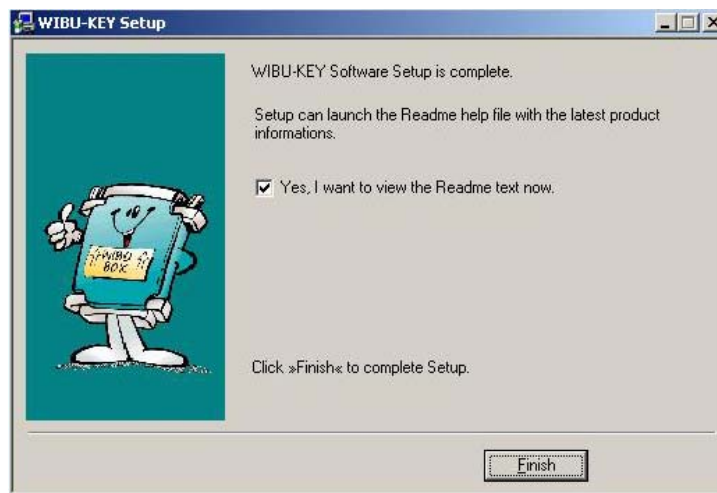

11. Click “Finish”

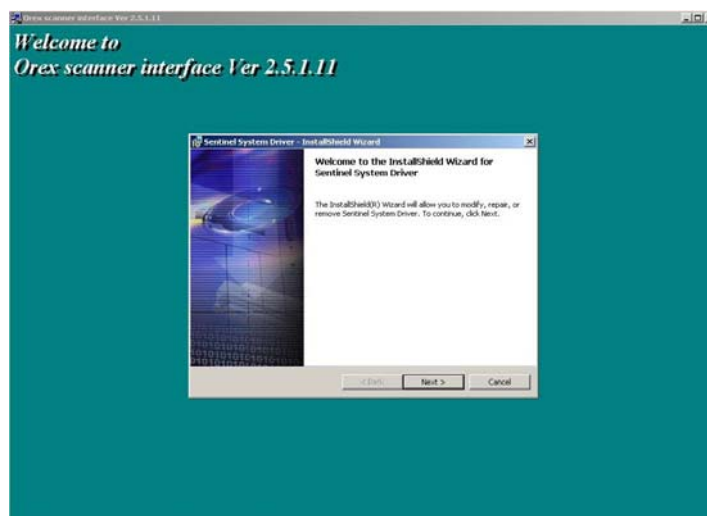

12. Click “Next”

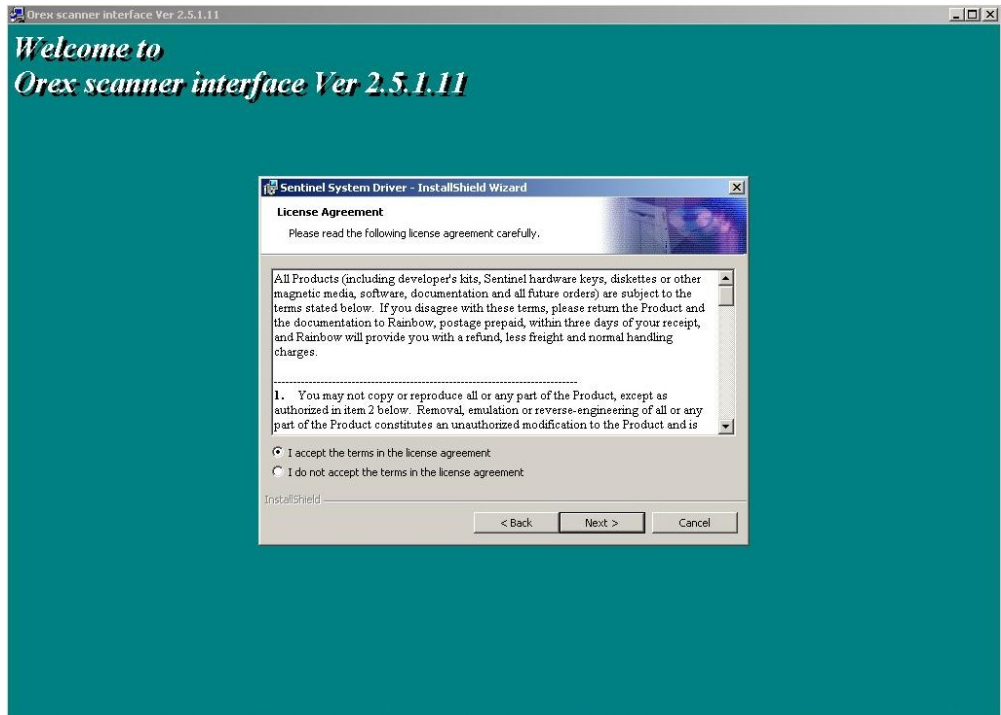

13. Choose “I accept the license “ and then click “Next”

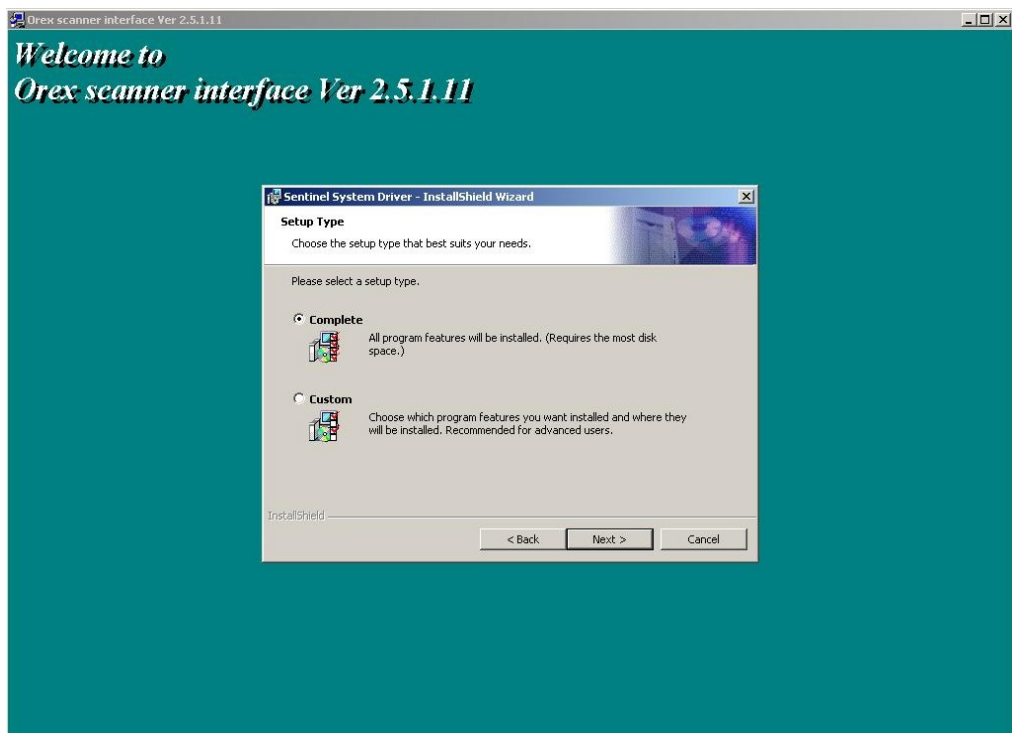

14. Choose the default option “complete “ and then click “Next”

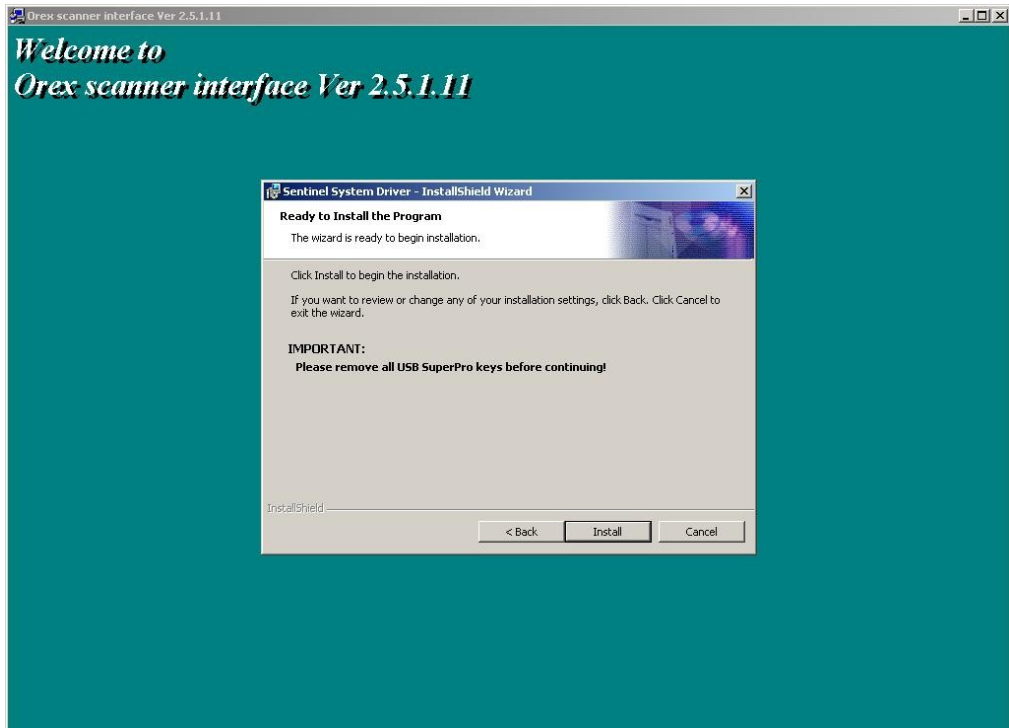

15. Click “Next”

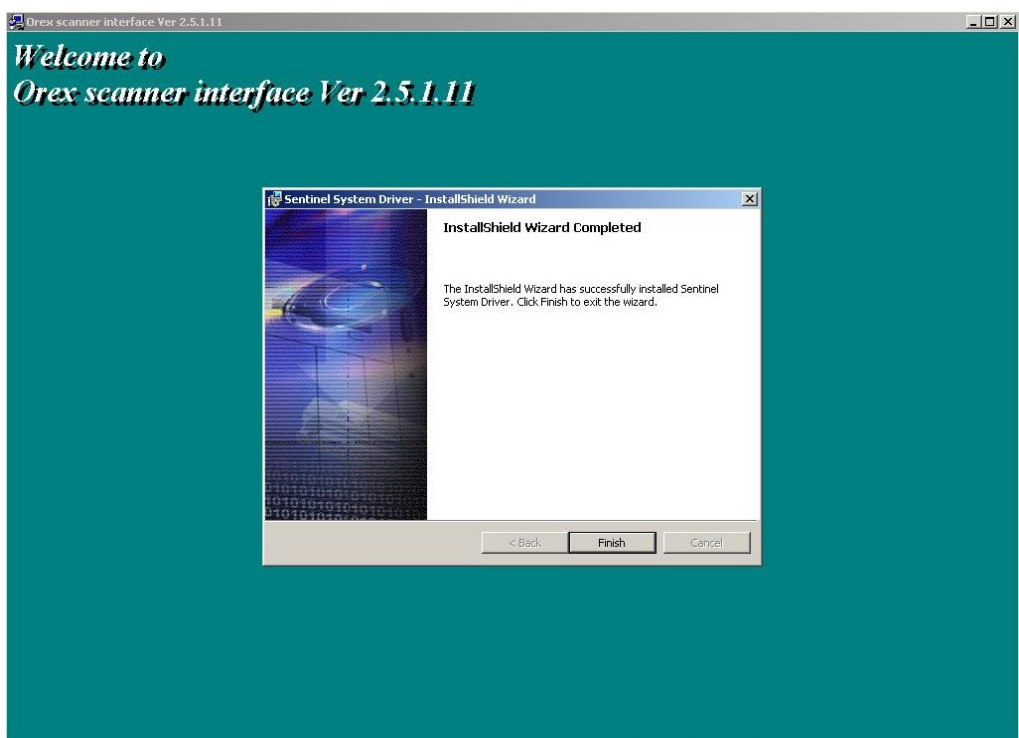

16. Click “Finish”

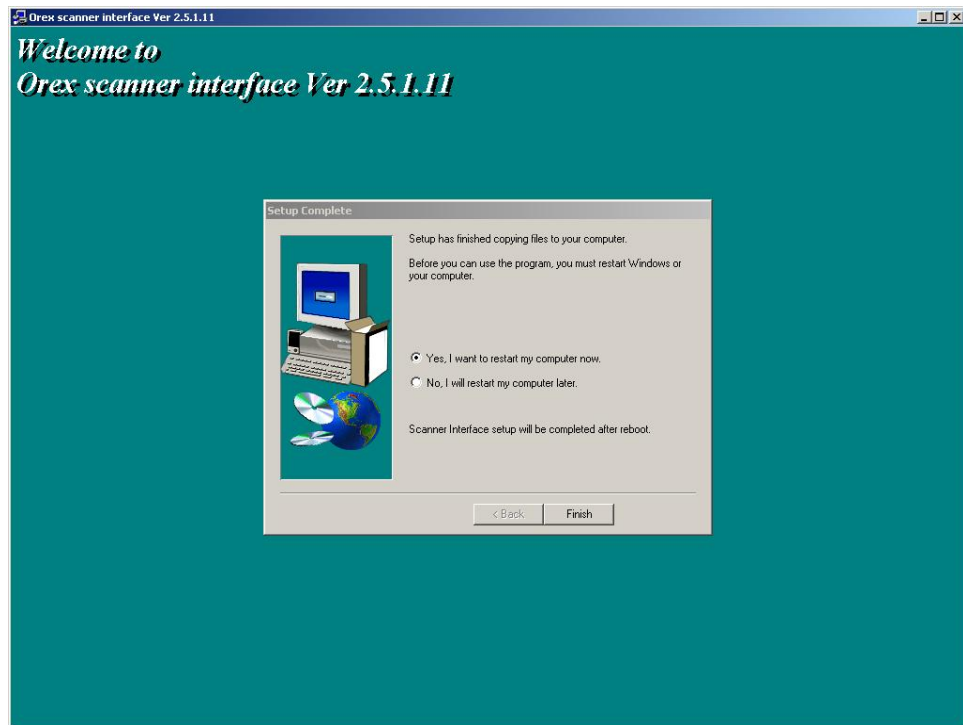

17. Choose “Yes, I want to restart my computer now” and click “OK”

4.4.4 Onyx-Rad Installation

The Onyx-Rad software is supplied on a CD separate from the “Scanner Interface” CD.

For installation of the Onyx-Rad software, refer to the detailed explanations in the Installation Manual located on the Onyx-Rad CD.

Note:

1. To function, the Onyx-Rad also needs the Dongle, installed in section 4.4.4. If the Dongle is not installed, or is not connected to the parallel/USB port, the software cannot run.
2. Restart the computer at the end of the Onyx-Rad installation.

4.4.5 Licensing the GOP Filters

This section can be applied ONLY after installing the Dongle. This process is performed automatically with the scanner interface software installation.

1. Plug the dongle to the parallel port on the back of the computer.
2. Insert the “Scanner Interface” CD into the CD-Rom drive.

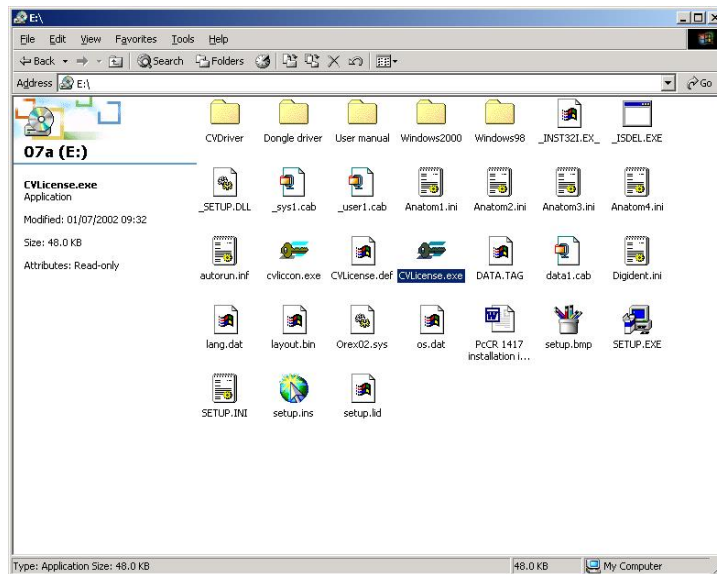

3. Double click the “CVLicense.exe” file.

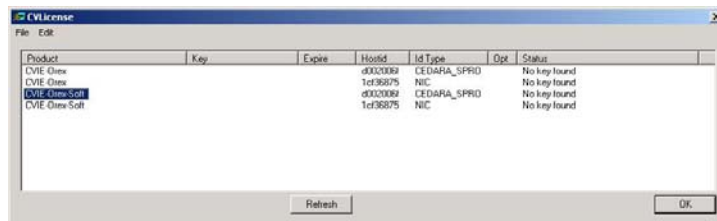
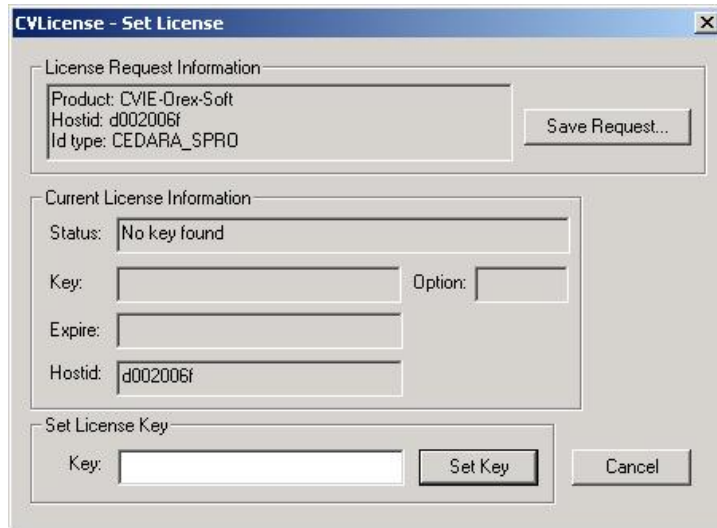
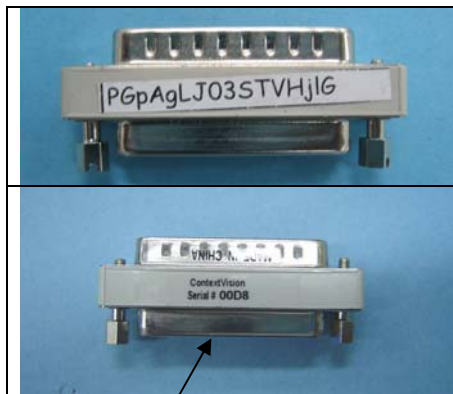

Figure 7: CVLicense Window Before GOP Licensing

4. A new window appears. Double click “CVIE-Orex-Soft” (5rd line).



5. The licensing window appears. Enter the code supplied by Orex into the “Key” dialog box. If you have not received the code, please contact your distributor. The code is unique, and depends on the SN of the Dongle, which appears on the dongle as a 4-digit number at the bottom line.



SN=00D8 (example)

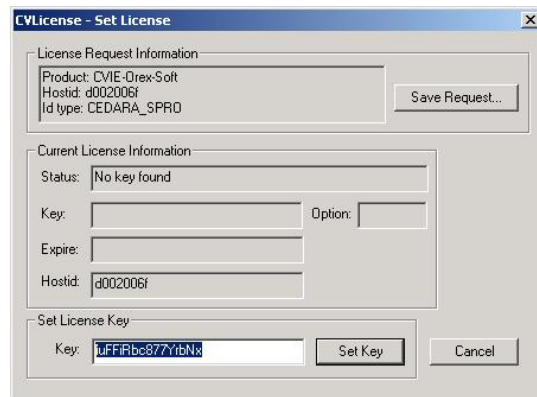

Figure 8: Setting the GOP License Key

6. Enter the code you received; then click “Set Key”.

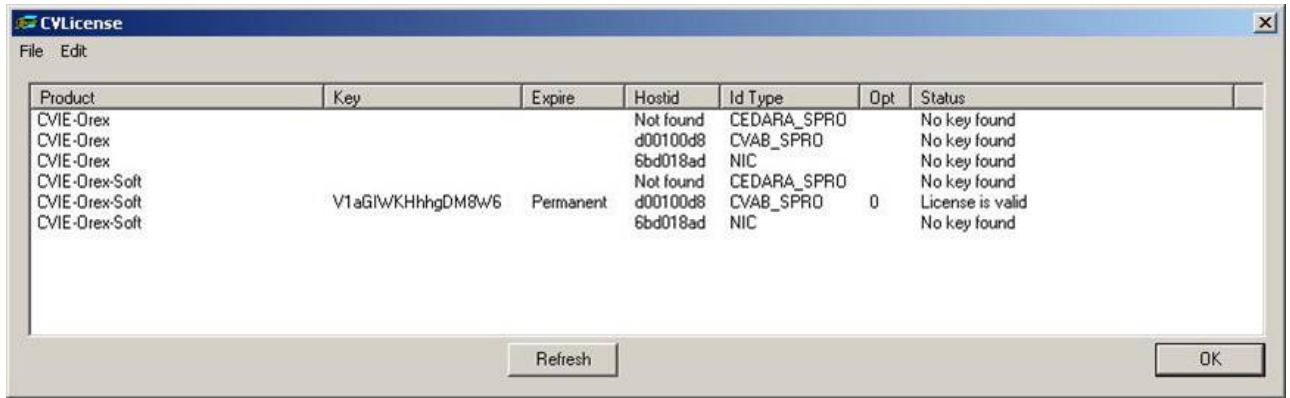

Figure 9: CVLicense Window after GOP Licensing

7. The previous screen appears again. This time the “CVIE-Orex-Soft” on the 5th row, the message “license is valid” should appear in the status column. If the status does not change to “license is valid” check the key that was entered again and confirm that small/big letters were written correct.

4.5 Installation Report

For the warranty of the PcCR 1417 to take effect, and in order to verify correct installation by Orex, you are required to fill out the installation form and fax/e-mail to Orex service department.

The installation form is located in Appendix C

Orex Contact Information

Israel:

Fax: (+972) -4- 9591262

Email: support@orex-cr.com

USA:

Fax: (+1) -617-244-8888

Email: supportusa@orex-cr.com

5. Scanner Interface Software

5.1 General

The Scanner Interface Software is a module that enables the FSE to access to the PcCR 1417 advanced setup, and the user to interface with the system.

Following is a list of screens, and their functionality:

5.2 Interface Description

5.2.1 Main Screen

This screen is used as the interface between the end user and the scanner.

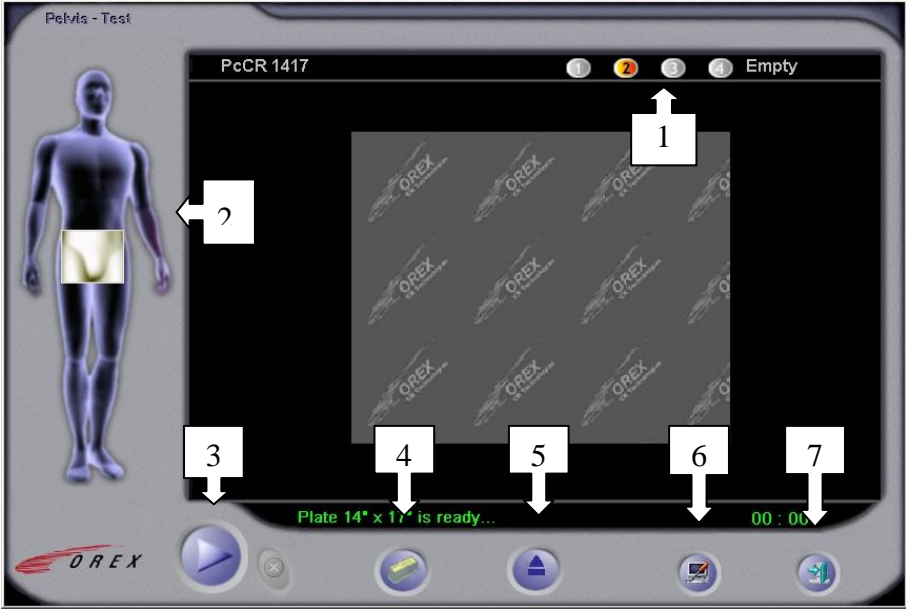



Figure 10: Scanner Interface, Main Screen

Title	Description
1. Unit	Click here to select the x-ray unit being used
2. Region	For selecting the anatomical region to which the image to be scanned, belongs.
3. Scan	Use to initiate the scan. During the scan a pre-view of the scanned image is displayed. At the end of the scanning process, the interface window closes

Title	Description
4. Erase	For erasing the image on the phosphor plate.
5. Eject	For unloading the plate; then ejecting the cassette.
6. Setup	<p>For entering the Setup interface. The login screen is displayed:</p>  <ul style="list-style-type: none"> • User password – None • Technician password – 9591 • Orex Technician password – Contact Orex Service Dept.
7. Exit	For exiting the PcCR 1417 interface.

5.2.2 Setup Anatomical

Note: Each setup relates to a specific part, to be scanned from a plate that originated from a specific x-ray machine.

To enter the Anatomical screen choose the “User” mode and click “OK”.

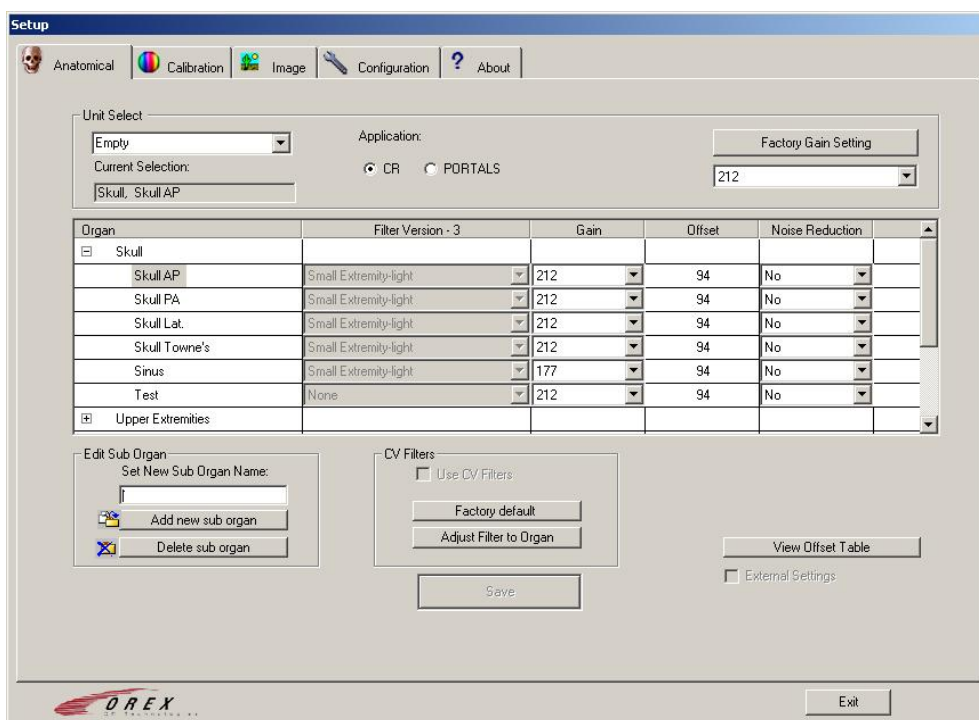

Figure 11: Setup Menu, Anatomical tab

Title	Parameter	Description
CR\PORTALS		CR – works with standard X-ray settings. PORTALS- works in RT mode.
Unit Select		The PcCR 1417 can support up to 4 different x-ray units. Each unit has its own set of parameters. Select/name the unit on which you want to work. You can change the unit name at any time

Title	Parameter	Description
Organ	Organ List	Select the required organ from the drop-down list. The following organs are available: <ul style="list-style-type: none"> • Skull • Upper Extremities • Chest • Abdomen • Spine • Lower Extremities • Abdomen
	Sub Organ List	Select the required sub-organ from the available list; this has to describe the image you want to scan. This is an initial list; you can add, and delete organs to any of the sub-organ lists (see the two buttons below).
Set new sub-organ name	Add new Sub-Organ	To add a new sub-organ: <ul style="list-style-type: none"> • Select the Organ. • Type the new Sub-organ. • Click Add.
	Delete Sub-Organ	To delete a sub-organ: <ul style="list-style-type: none"> • Select Organ. • Select Sub-organ. • Click Delete.
CV filter		Enable the option to apply automatically a filter for each organ individually.
Calibration Settings	Pm Gain	For performing Automatic Calibration. Refer to the Calibration chapter in the User Manual.
	Set PM Gain First Calibration Settings	Refer to the Calibration chapter in the User Manual.
Sub Organ Acquisition Setup	PM Gain calibration	After performing the automatic calibration process, it is possible to fine-

Title	Parameter	Description
	Offset	<p>tune the image.</p> <p>If the image is too dark, increase the value by 10 numbers.</p> <p>If the image is too light, decrease the value by 10 numbers.</p> <p>Indicate the current Offset calibration, (for more details refer to the User Manual).</p> <p>Do not change this value.</p>
External Settings		For using settings pre-defined by an external software application.

5.2.3 Setup Image

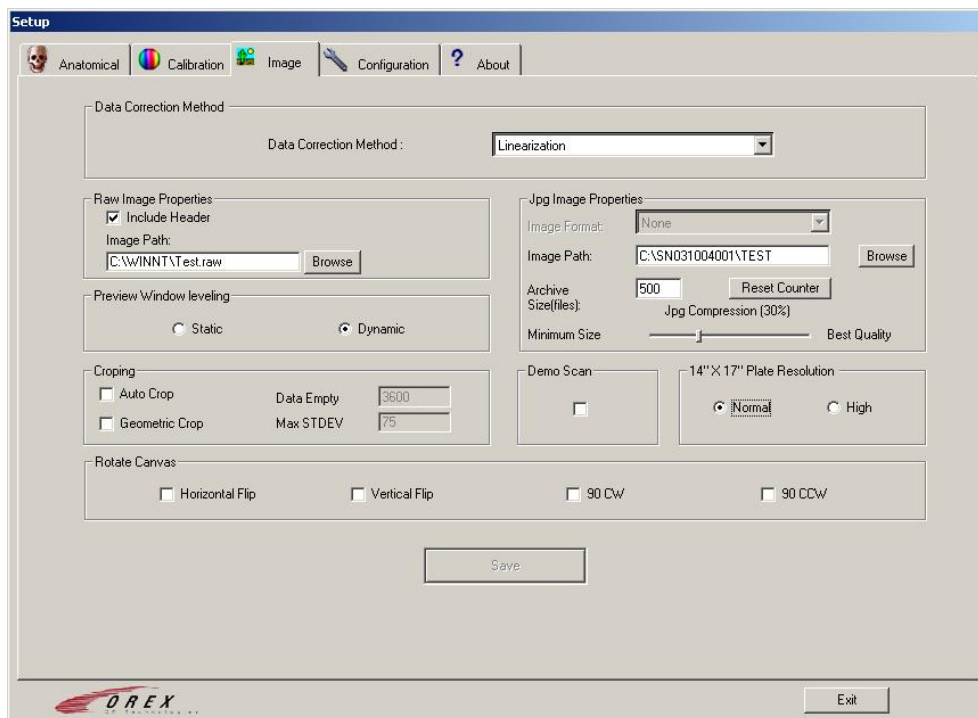

Figure 12: Setup Menu, Image tab

Title	Parameter	Description
Jpg image properties		Enable the option to save the image as a jpeg file.
Data Correction Method	Data Correction Method	For changing the data correction method. The recommended method is Linearization.
Demo Scan		For using an available image file for scanning, if no plate (cassette) is available.
Rotate canvas	Horizontal flip Vertical flip	For flipping the image.

5.2.4 Setup Configuration

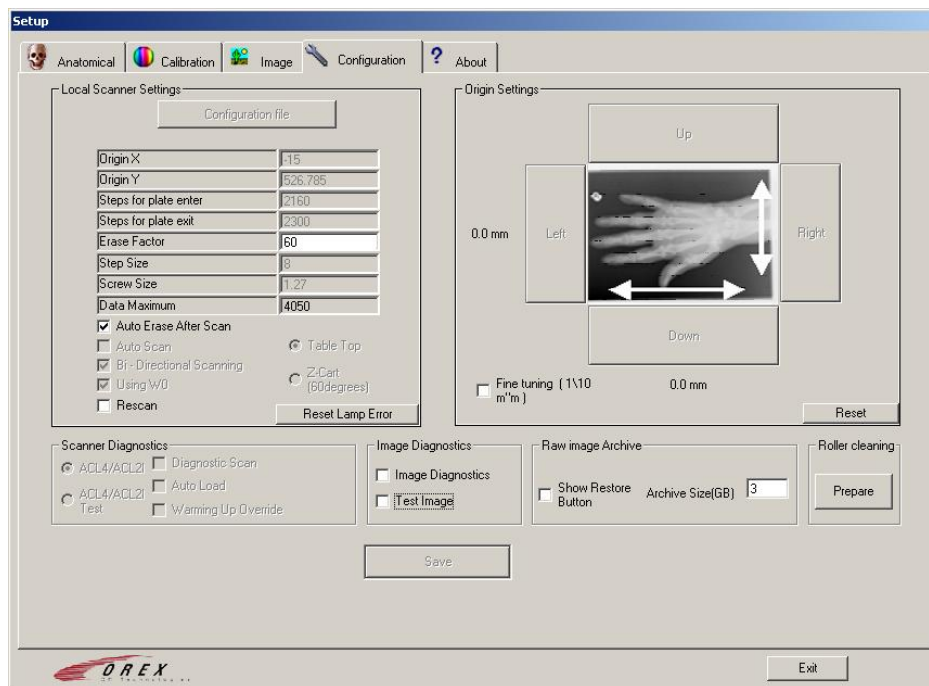

Figure 13: Setup Menu, Configuration tab

Title	Parameter	Description
Local Scanner Settings	Configuration file	Opens the configuration file with Notepad.
	Origin X	X-axis home, where the scanner begins to scan the plate.
	Origin Y	Y-axis home, defines the location where the plate enters the scanner.
	Steps for Plate Enter	Defines the number of steps for the loader to return the plate into the cassette.
	Steps for Plate Exit	Defines the number of steps for the loader to extract the plate from the cassette.

Title	Parameter	Description
		files\orex\ACL4SB\archive
Warming up override		Option for technicians to disable the lamp warming up process

5.2.5 Setup Operation Update

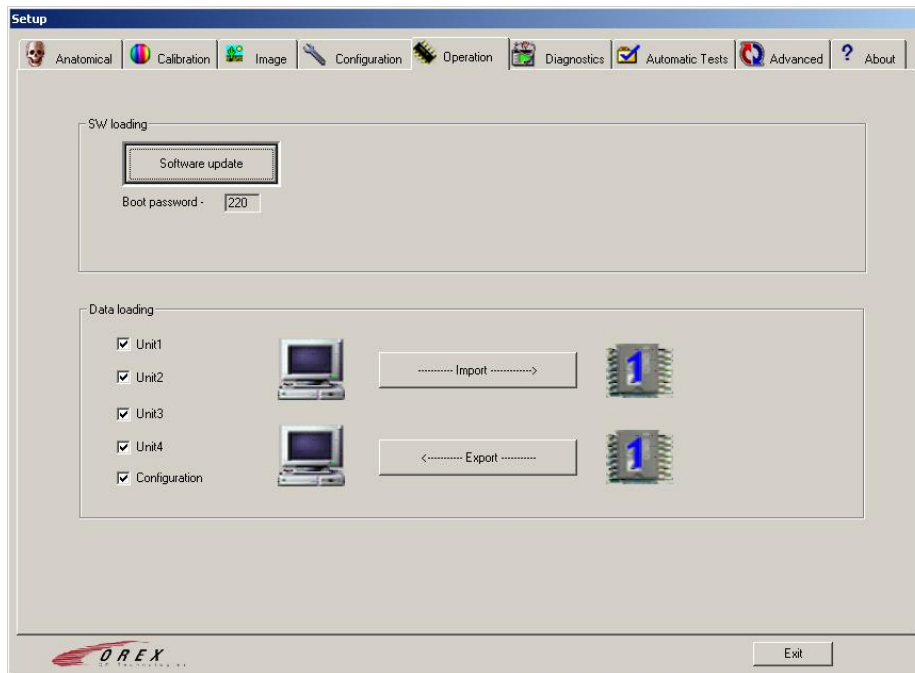

Figure 14: Setup Menu, Operation Update tab

Title	Parameter	Description
Unit 1-4 Backup		Use to select the desired unit for performing backup, or restoring
Configuration Backup	A. PC Backup B. Memory backup	Backup of data to a PC. Backup of data to serial EPROM
Update Main Firmware	Software Update Boot Password	Click the Software update button to update the software to the scanner. Displays the Boot password.

5.2.6 Setup Diagnostics

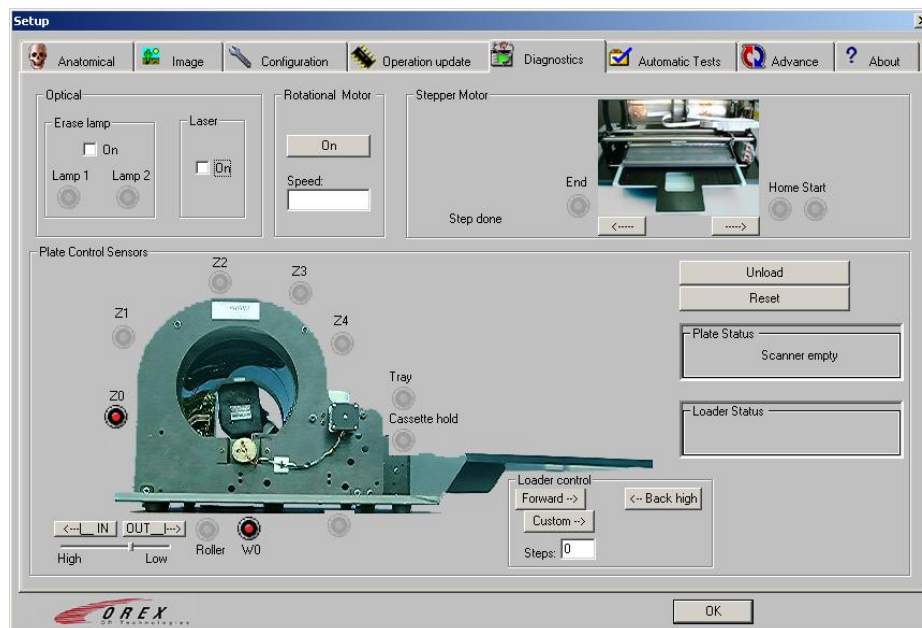

Figure 15: Setup Menu, Diagnostics tab

Title	Parameter	Description
Optical	Erase Lamp	Turn on/off the Erase lamp
	Lamp1	Indicates that lamp1 is on.
	Lamp2	Indicates that lamp2 is on.
	Laser	Turns on/off the Laser unit
Rotational Motor	On	Turns on the Rotational motor
	Speed	Indicates the speed of the rotational motor.
Stepper Motor	← →	Each click moves the carrier in the selected direction. When the carrier approaches its travel limit, it activates a limit switch (red indicator).
	End Start	

Title	Parameter	Description
Plate Control Sensors	<p>Sensors</p> <p>Cassette in place – Cassette is docked</p> <p>Cassette hold – Cassette is locked</p> <p>Loader back– Loader has reached plate</p> <p>W0 – Plate is approaching rollers; has to slow down</p> <p>Roller – Feeding rollers</p> <p>Z0-Z4 – Positioning sensors</p> <p>← →</p> <p>In Out</p> <p>High/Low slide-bar</p> <p>Unload</p> <p>Reset</p> <p>Plate Status</p> <p>Loader Status</p>	<p>Moves the plate In or Out of the scanner.</p> <p>Controls the movement speed of the plate in the scanner.</p> <p>Unloads the cassette</p> <p>Resets all the sensors and motors in the Diagnostic menu.</p> <p>Displays the status of the plate</p> <p>Displays the status of the plate loader</p>
Loader Control	<p>Forward</p> <p>Back High</p> <p>Back Low</p> <p>Custom – Steps</p>	<p>Moves the Loader forward</p> <p>Moves the Loader into the cassette. Each click moves it the number of steps typed into Steps.</p>

5.2.7 Setup Automatic Tests

This menu is used primarily, at the end of the Orex production line, for burn-in tests.

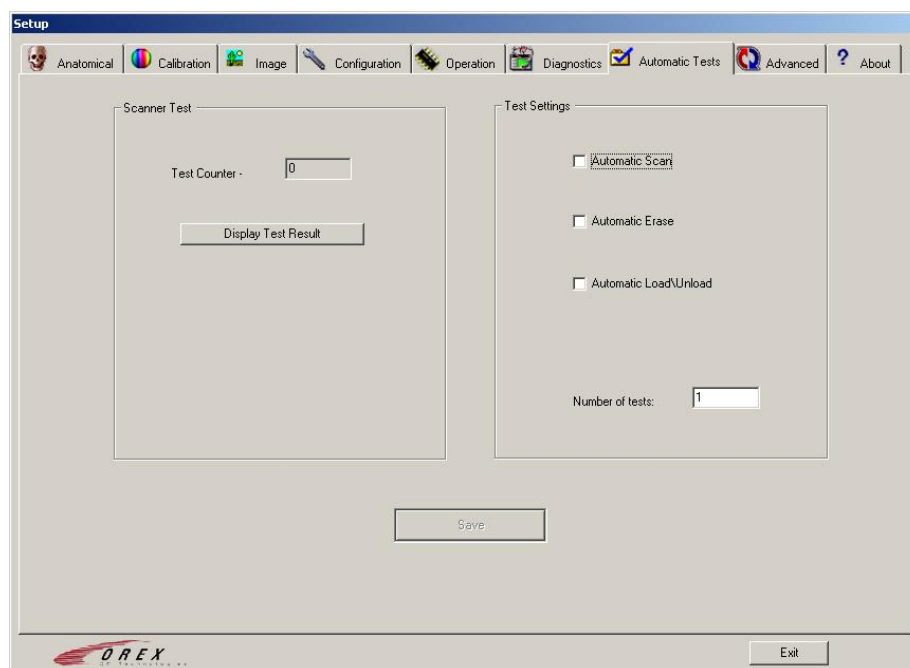

Figure 16: Setup Menu, Automatic Tests tab

Title	Parameter	Description
Scanner Test	Test Counter	Displays the number of tests that have been run.
	Display Test Result	Displays the test results.
Test Settings	Automatic Scan	Performs a scan automatically, when the cassette is inserted into its port. This test is usually run with the Automatic Load/Unload test
	Automatic Erase	Performs an automatic erase.
	Automatic Load/Unload	Automatically Loads and unloads the plate. This test is usually run with the Automatic Scan test.
	Number of tests	Sets the number of tests to run.

5.2.8 Setup Advance

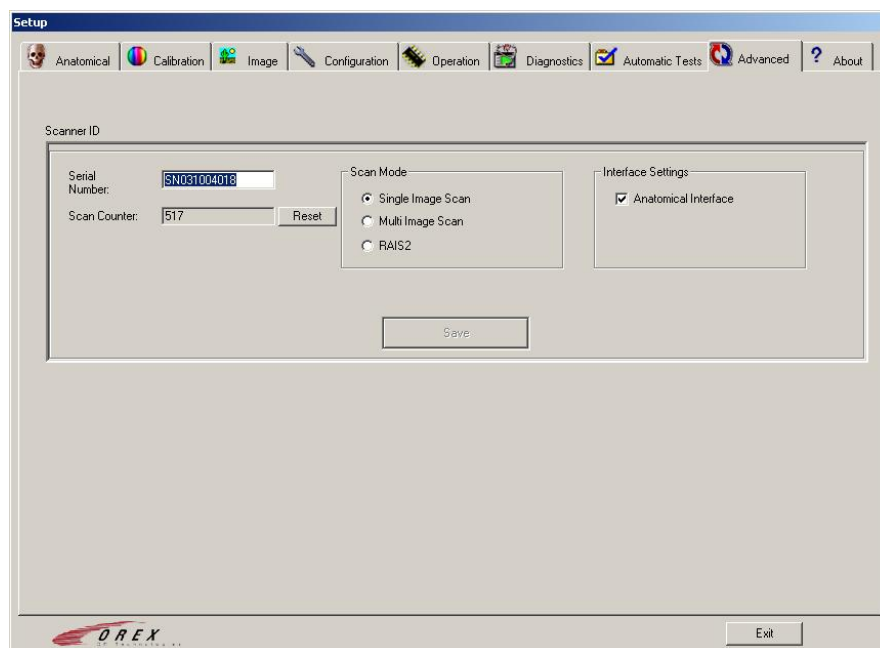

Figure 17: Setup Menu, Advance tab

Title	Parameter	Description
Scanner ID	Serial Number	From here you can edit the serial number, and the DV number.
	DV Number	Displays the serial number of the system.
	Scan Counter	Displays the number of scans performed.
	Reset	Resets the number of scans to “0”.
Scan mode	Single mode	One image at a time is saved after scan process is finished to the database.
	Multi image scan	Scan several images before transferring them to the database.
	RAIS2	Dual scan mode – two scanners connected to the same computer
Interface Settings	Anatomical Interface	Check for the body image on the main screen. Uncheck for test-labeled buttons. The labels can be renamed by using the Orex Editor.

Title	Parameter	Description
Save		For saving the parameters. This HAS to be done before selecting another tab.

5.2.9 Setup About



Figure 18: Setup Menu, About tab

Title	Parameter	Description
Software Version	1. Motion	Currently used version of the Motion board
	1.1 USB (FPGA)	Currently used version of the USB (FPGA).
	2. Firmware (boot)	Currently used version of the Firmware (boot)
	3. Firmware (Motion)	Currently used version of the Firmware (Motion)
	4. Driver	Currently used version of the Driver
	5. Scanner Interface	Currently used version of the Scanner Interface
	Anatomical database	Currently used version of the Anatomical database

Title	Parameter	Description
Scanner ID	Serial number	Scanner serial number
	Scan counter	Number of scans been done

5.2.10 Image Diagnostics

For performing final calibration of the filters assigned to the displayed part (sub-organ), after scanning the desired image is displayed on the mini viewer.

The results can be seen immediately, as opposed to the Setup screens where the results are not immediately visible.

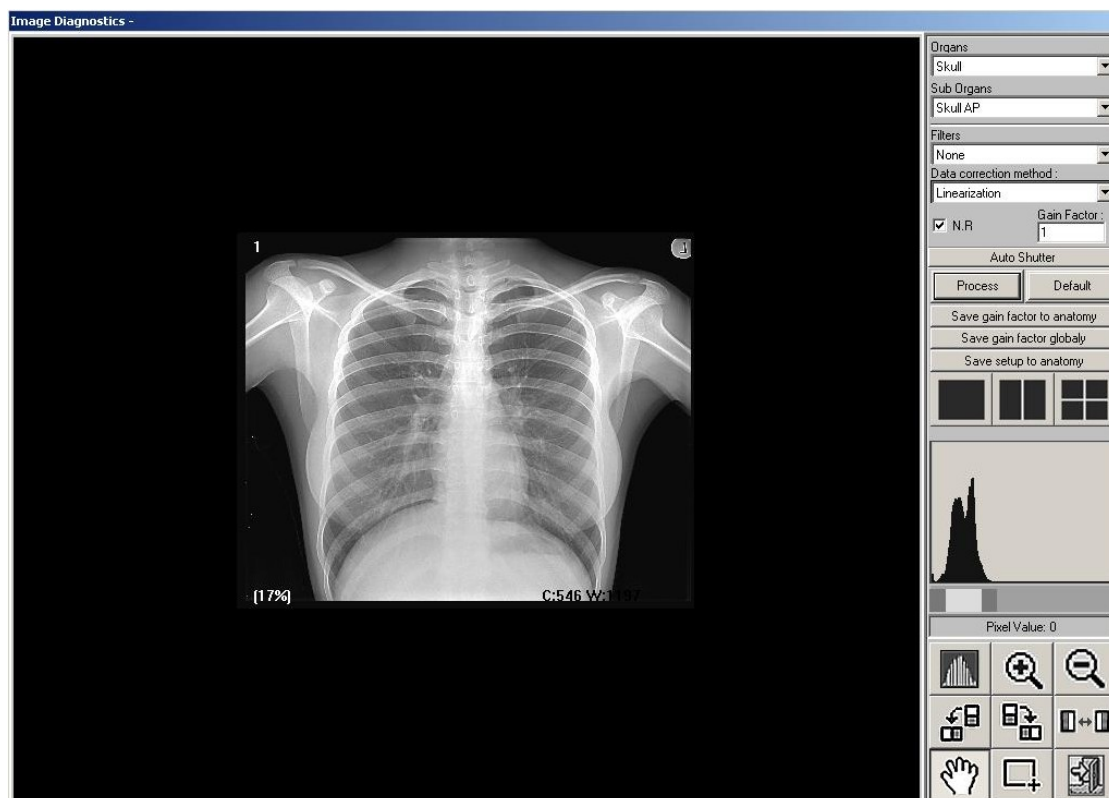

Figure 19: Image Diagnostic screen (Mini Viewer)

Title	Parameter	Description
Organ Selection	Organ	For selecting the main classification (organ)
	Sub Organ	For selecting the actual (viewed) sub-organ
Image Adjustments	Filters	Use to select the filter.

Title	Parameter	Description
	Data Correction method	For changing the data correction method. The recommended method is Linearization.
	Data minimum	For changing the Data Minimum.
Process		For viewing the result of the new setup
Reset		For resetting the image
N.R		Noise reduction
Auto shutter		Eliminate white borders around the image.
Gain factor		This parameter moves the histogram to the desired location on the graph and sets the new PM gain value in the Anatom.ini file.
Histogram		To view the histogram of the displayed image
Save		To save the settings.
Exit		To exit the mini-viewer.

5.2.10.1 Using the Image Diagnostics Functions

1. Select the correct **Sub-organ** from the relevant **Organ**.
2. Select the desired **Filter**; then click **Process** to view the filtered image.
3. You can now right-click and drag to change contrast and intensity; or click and drag to change zoom. The cursor changes accordingly. Alternatively, you can use the sliders at the bottom right of the screen.
4. If the result is not satisfactory, you can click **Reset** to reset the image; then repeat the procedure with another filter, until you get the best image.
5. When the desired image quality is attained, click **Save**. Whenever this part is selected for scanning under this unit, the image will be filtered at this saved quality.

It is possible to view the histogram of the image.

In addition, for each sub-organ you can set a Data Minimum value.

6. Troubleshooting

	Problem	What should I do?	Remarks
1.	“Disconnect” error message appears on the “scanner interface” screen	1. Check: Power cable connected? USB cable connected? 2. Turn system off; then on again.	
2.	Onyx-Rad software does not load. Error message received	Check if Dongle is connected to the parallel port of the PC	See also: Chapter 4: Installation
3.	GOP filters do not apply on the image	Make sure that the GOP filters are licensed	See also: Chapter 4: Installation
4.	After the system is turned on, initialization sound does not stop.	Turn system off; then on again. If the problem persists, contact your distributor.	
5.	Cassette cannot be inserted into the tray.	Make sure the cassette is positioned at the center of the tray.	
6.	Image is too bright.	From the Scanner Interface – Setup menu, increase “PM-Gain” for the type of image which is too bright	See also: User Manual – Chapter: Using the scanner interface
7.	Image is too dark	From the Scanner Interface – Setup menu, and decrease “PM-Gain” for the type of image which is too light	See also: User Manual – Chapter: Using the scanner interface
8.	Double image received	1. Check that the erase lamps are working 2. If the erase lamps are OK, increase the erasing factor by 5 from the Scanner Interface – Setup menu → Configuration	
9.	White lines appear on image.	Contact Orex service department	
10.	Horizontal lines appear on image	Contact Orex service department	
11.	Scan does not start	Contact Orex service department	
12.	Systems is shaking	Place system on steady surface	
13.	Diagonal lines appear on image	There is light penetration into the system. Place the system away from intense light source (window).	See also Chapter 3: Site Preparation

7. Appendix A: Installation Prerequisites

PRE-INSTALLATION FORM

Computer requirements:

PC:	
CPU – Pentium 4, 1.8GHz (min.)	
RAM – 256MB	
Hard-Drive – 40GB	
Operating System:	
Windows 2000	
Monitor:	
Size – 17” (min.)	
Resolution – 1024x768 (min.)	
Ports:	
USB port available	
NO USB mouse or keyboard	
Parallel port	
Additional:	
Network adapter (for Dicom send)	

.1 Space requirements

Stable surface	
Width – 100 cm	
Height – 50 cm	
Depth – 80 cm	

Electrical requirements:

Voltage – 90-250 VAC	
Frequency – 50-60 Hz	
UPS – Online, 500 VA	
UPS connected to CR system, PC, Monitor	

.2 Environmental requirements

Temperature – 18°C-30°C normal lab conditions	
Humidity – 80% non condensing	
Light – less than 1000 Lux	

Configuration requirements:

Name off PACS on the site *	
Dicom send required?	Yes / No
Dicom Print required?	Yes / No

Single Media Archive required?	Yes / No
--------------------------------	----------

- When using the PcCr 1417 with a main PACS on site, the images are Dicom sent to the PACS. Please verify with Orex the compatibility of the PACS to Orex software.

8. Appendix B: Installation Report

INSTALLATION REPORT

Reporting distributor:

Company name:		
Technician installing the PcCr 1417:	Name:	
	Tee. No.:	
	e-mail:	

Site information:

Name:	
Address:	
Tel. No.:	
Additional information:	

Installation pre-requisites:

Date:	
SN of system installed	
Computer requirements met ?	
Space requirements met ?	
Electrical requirements met ?	
Environmental requirements met ?	

* See Installation pre-requisites, Appendix B

Installation process

Drivers for CR	
Scanner interface	
Or-Acquire	
GOP drivers **	
GOP licensing **	

** Optional

Accessories (PLEASE SPECIFY QTY.)

14x17 cassettes	
14x14 cassettes	
10x12 cassettes	
8x10 cassettes	

Onyx-Rad

Dicom send ***	
Dicom print	
SNA	

*** Please specify name of PACS to which the images are sent

Name: _____

Signature: _____